

Top view of fuselage

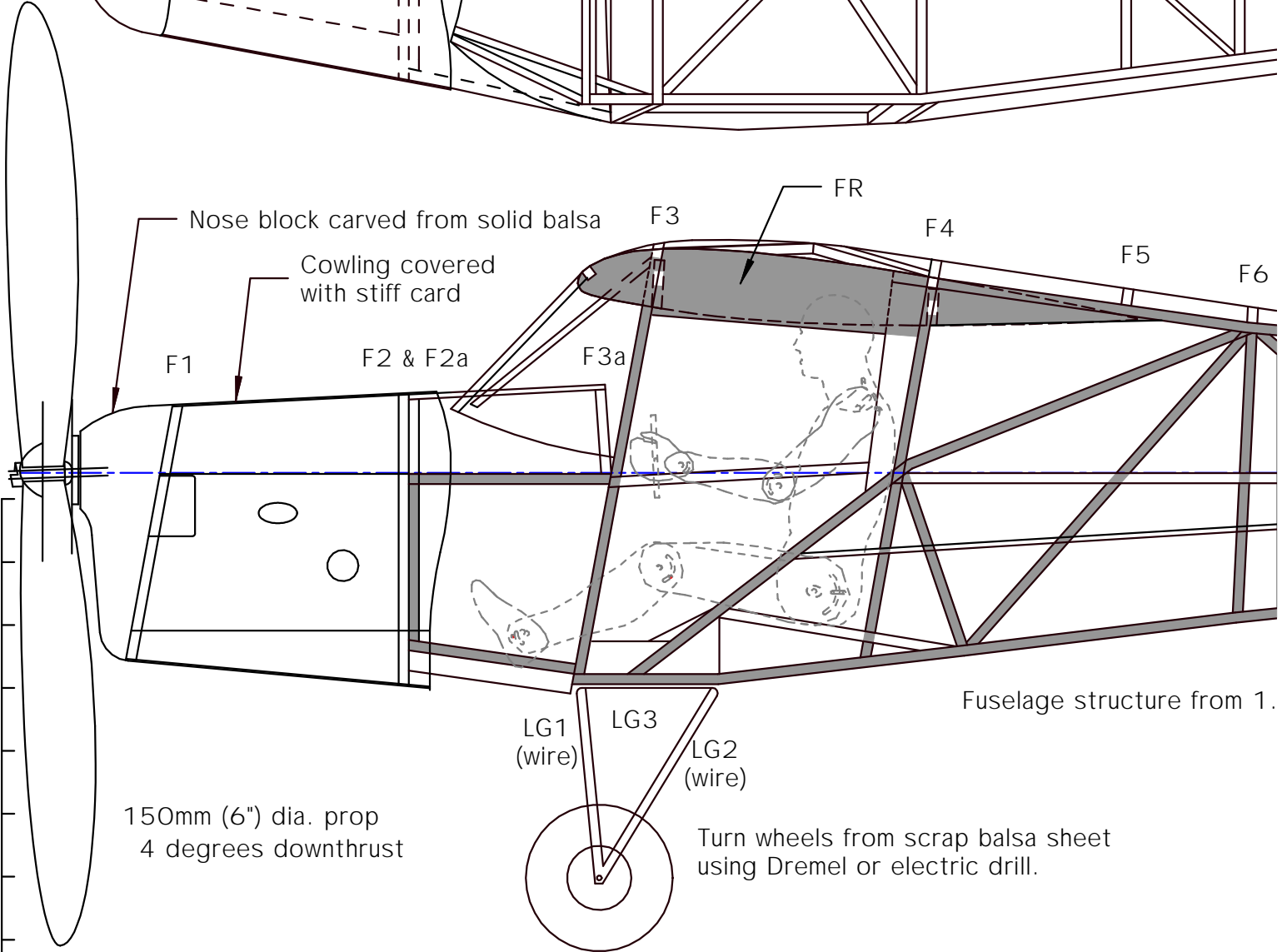

Underside view of fuselage

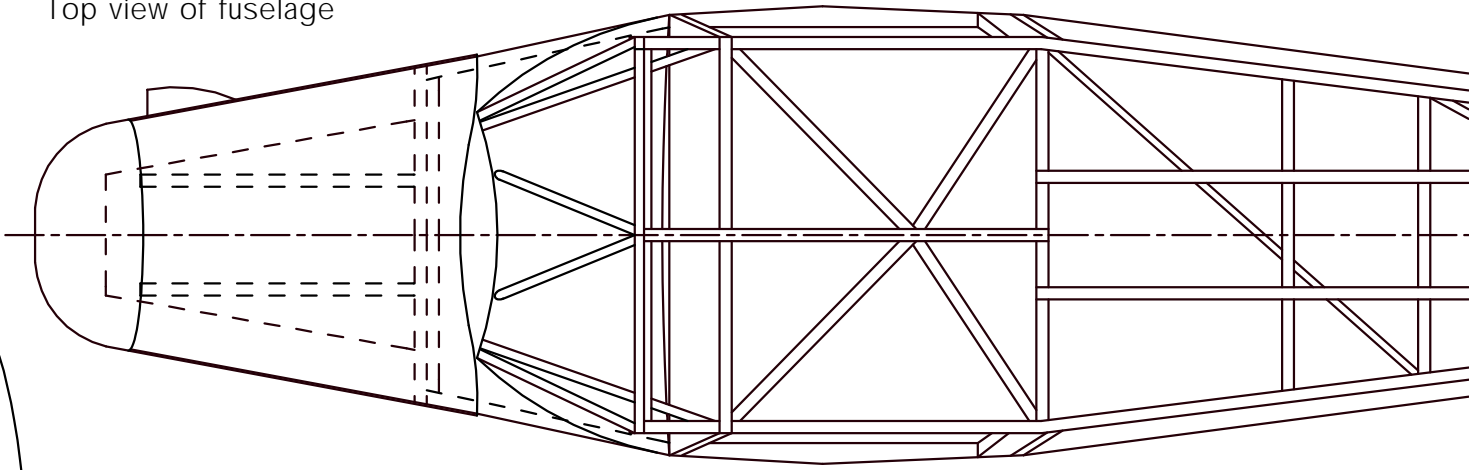
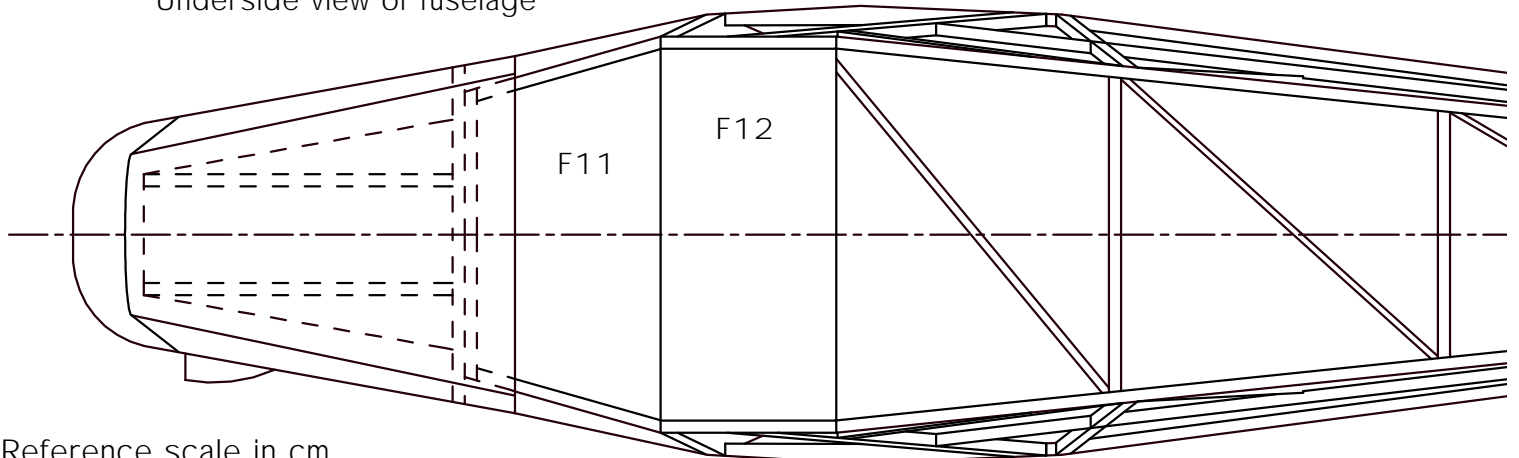

Reference scale in cm



Stringers from 0.8 x 1.6mm strip

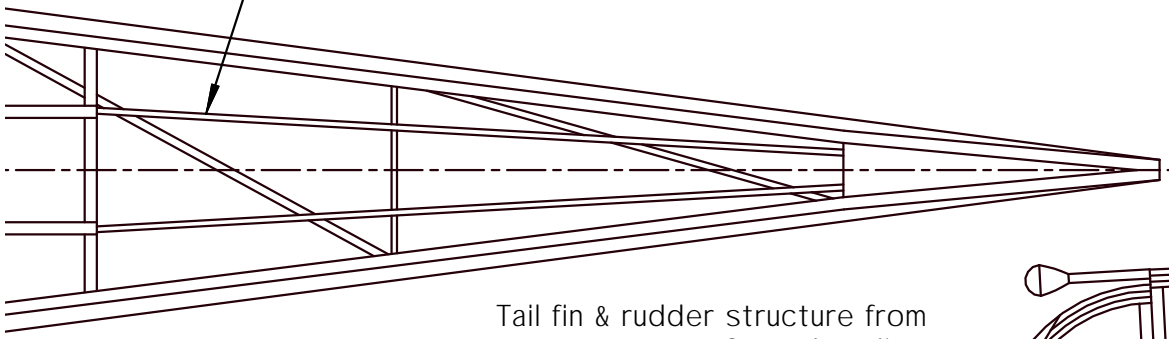

Tail fin & rudder structure from 1.6mm square. Curved outlines laminated from 3 layers of 1.6mm x 0.8mm balsa.

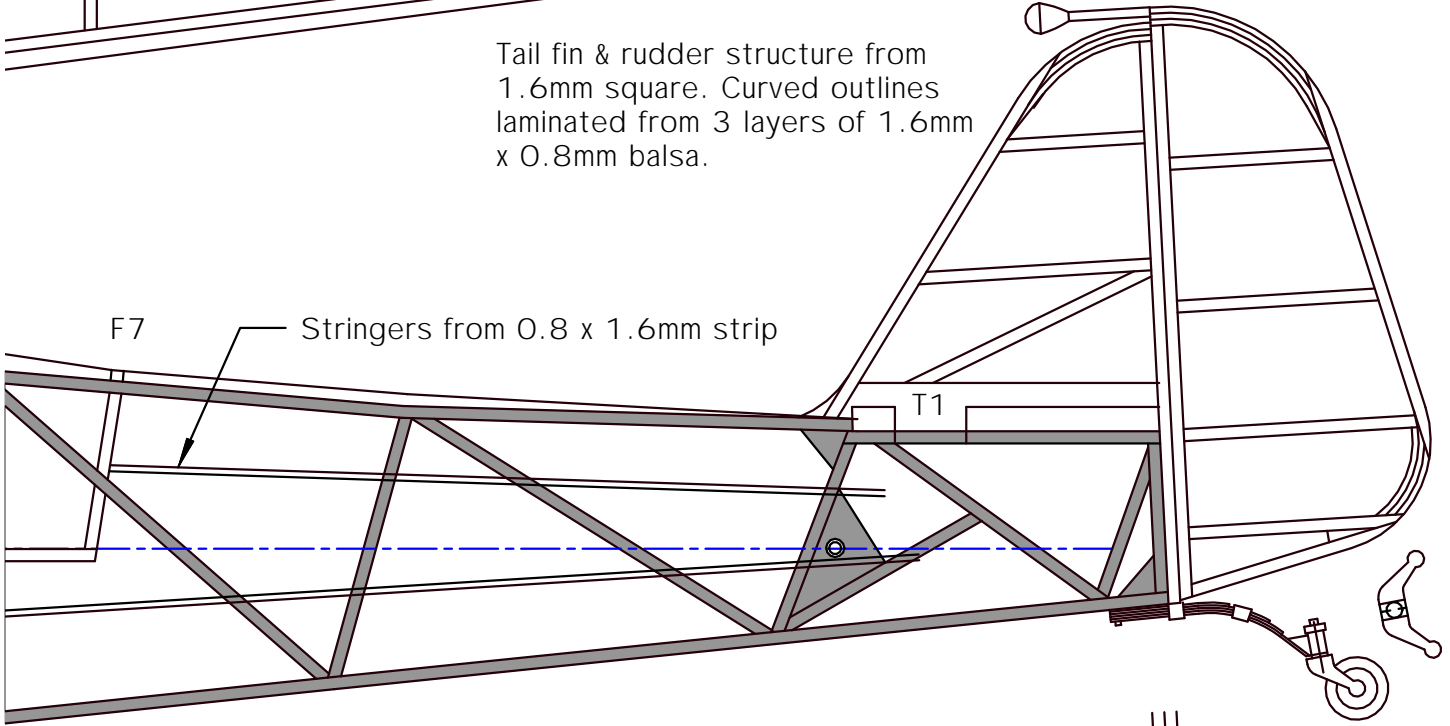

F7

Stringers from 0.8 x 1.6mm strip

T1

6mm square unless noted

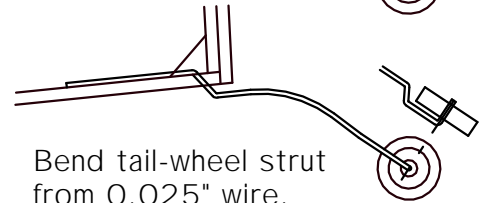

Bend tail-wheel strut from 0.025" wire. Laminate spring from thin card over wire.

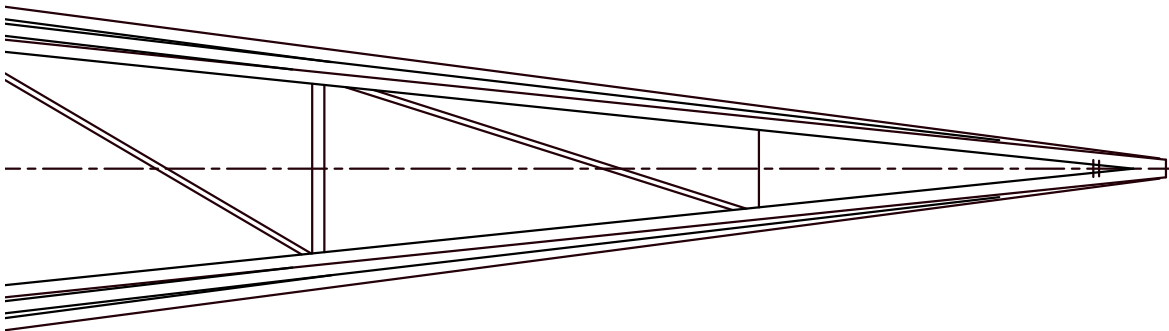

LG3  
1.6mm sheet  
(2 off)

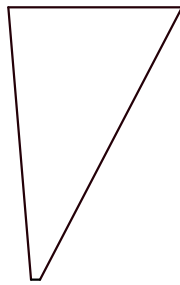
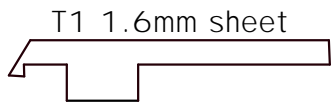
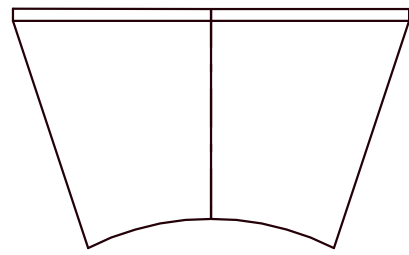

Front view  
of nose block

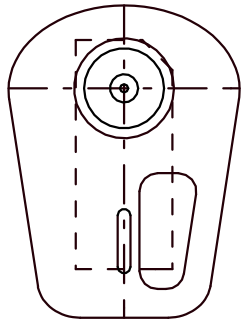

F1 1.6mm

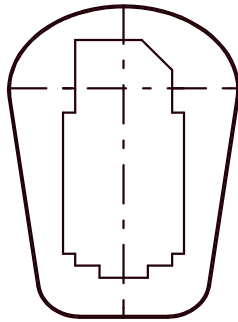

F2 1.6mm

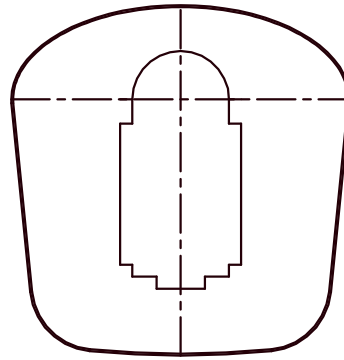

F2a 1.6mm

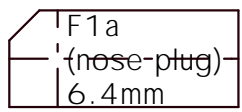
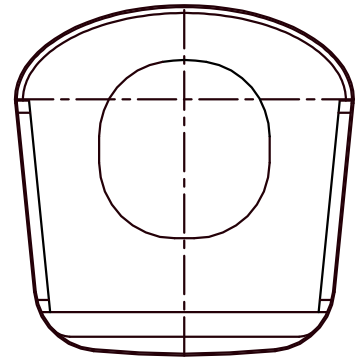

F1a  
(nose-plug)  
6.4mm

F3S 1.6mm (2 off)

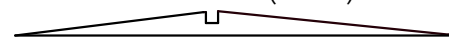

F7T

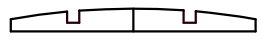

F3A 1.6mm

F6T

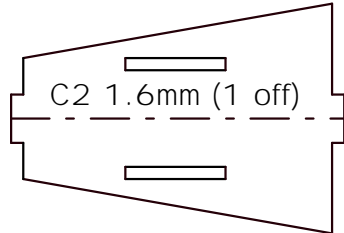
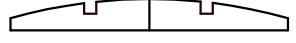

C2 1.6mm (1 off)

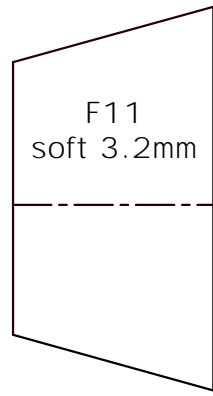

F11  
soft 3.2mm

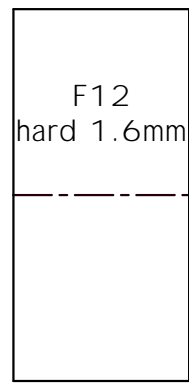

F12  
hard 1.6mm

F5T

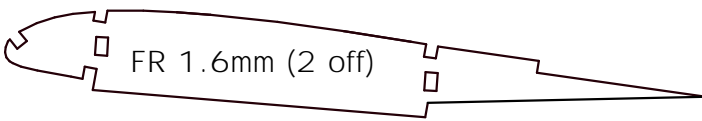

FR 1.6mm (2 off)

F4T 1.6mm

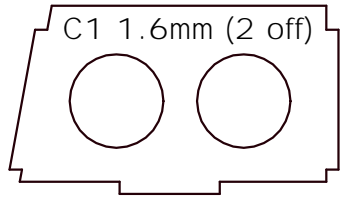
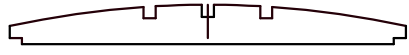

C1 1.6mm (2 off)

F4S 1.6mm (2off)

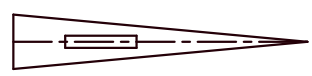

F4L 1.6mm (2 off)

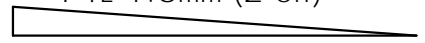

Section at F3

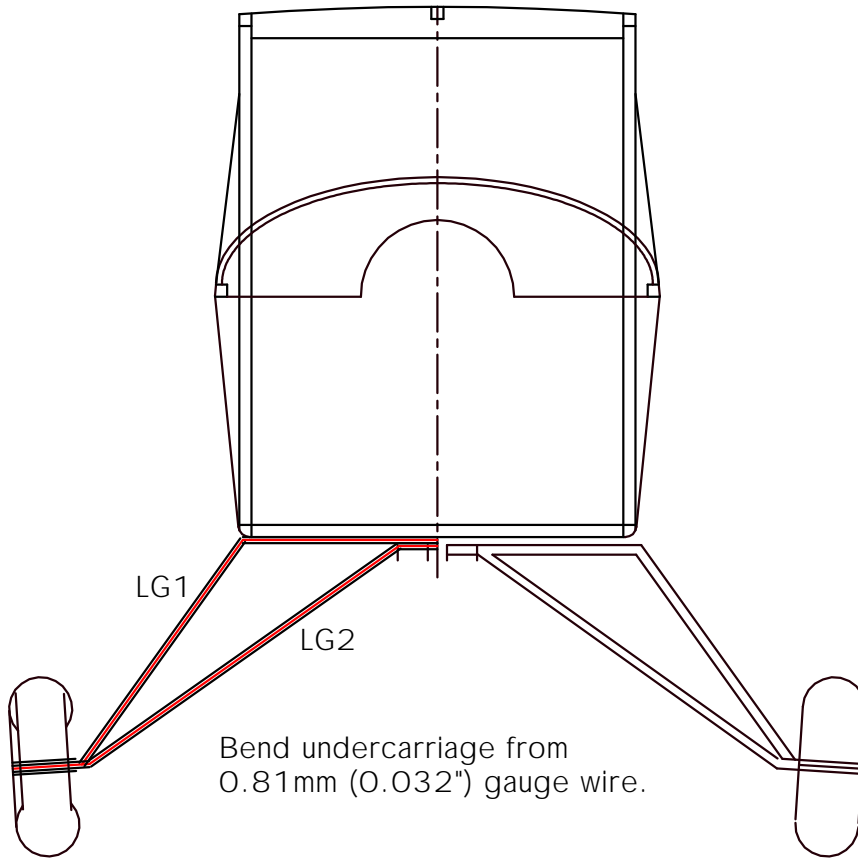

Section at F4

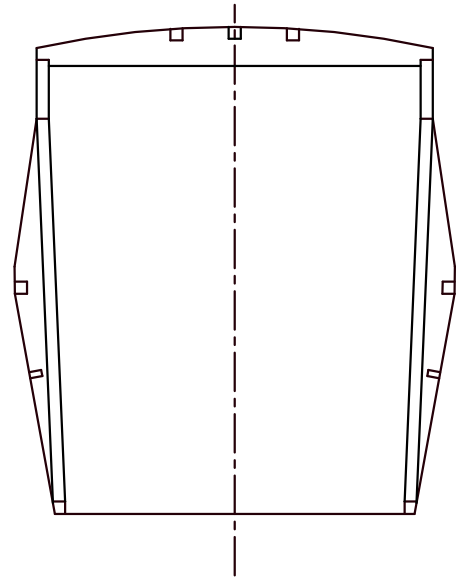

### Taylorcraft Aeroplanes Auster Mk III

Dimensions:	Prototype:	Model:	
Span:	10.97m	610mm	(24.0 in)
Length:	7.11m	xmm	(x in)
Wing area:	15.7 sq. m	4.82 dm <sup>2</sup>	(74.9 in <sup>2</sup> )
T/O Weight:	871 kg	40 g	(1.4 oz)
Scale:		1 : 18	
Model designed by Derek Buckmaster March 2002			



© D Buckmaster 2002  
[www.hotkey.net.au/~ue626](http://www.hotkey.net.au/~ue626)

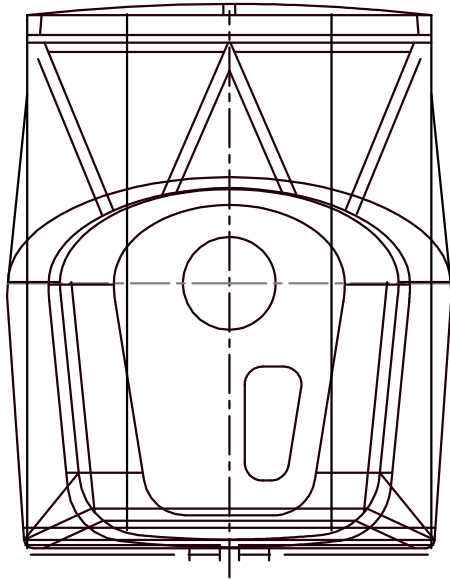

LG1 0.025"  
Piano Wire



LG2 0.025"  
Piano Wire

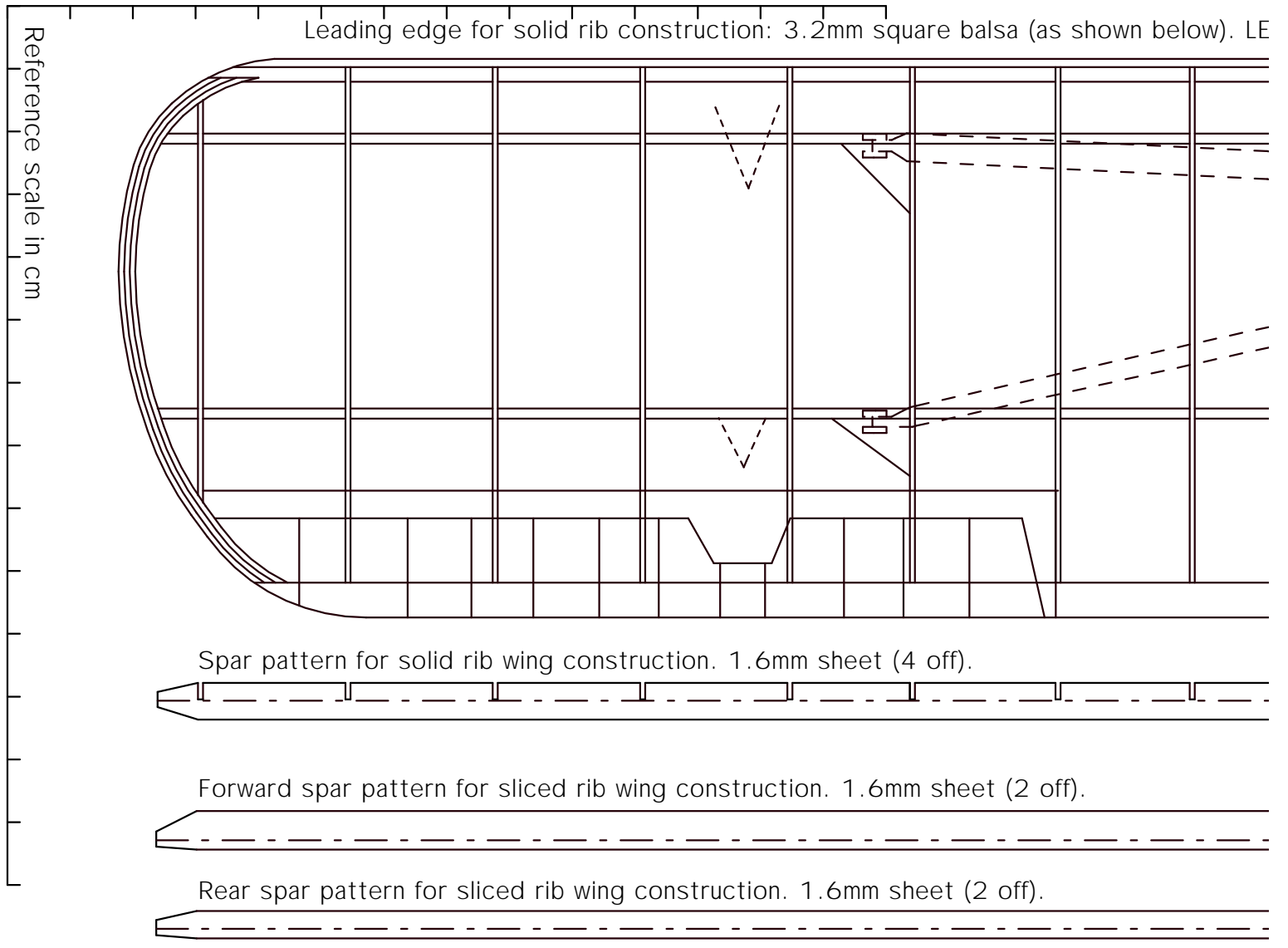

Rib and spar locations are same as full sized aircraft.

Dihedral: 8.4mm (11/32")

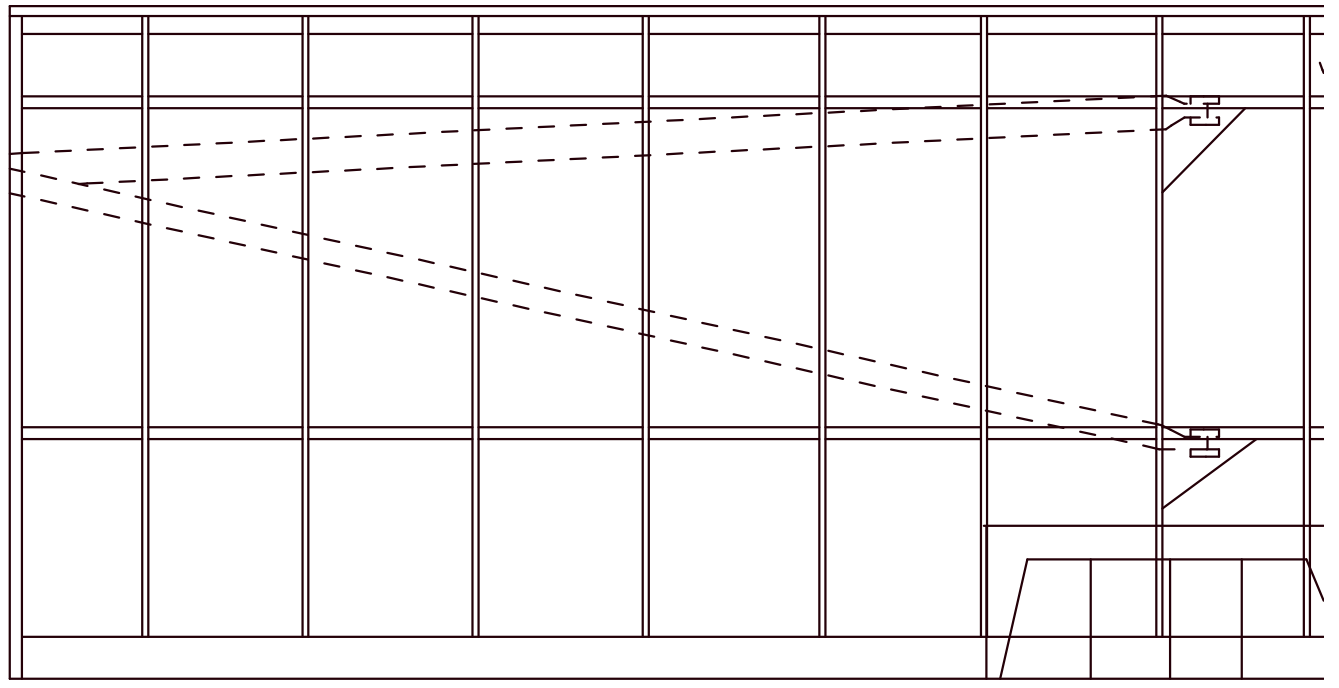

Trailing edge 1.6mm x 5.5mm

for sliced construction: 3.2mm x 5.7mm balsa.

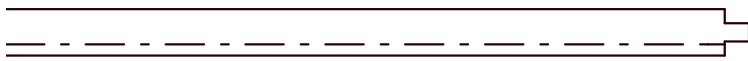
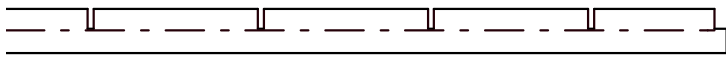
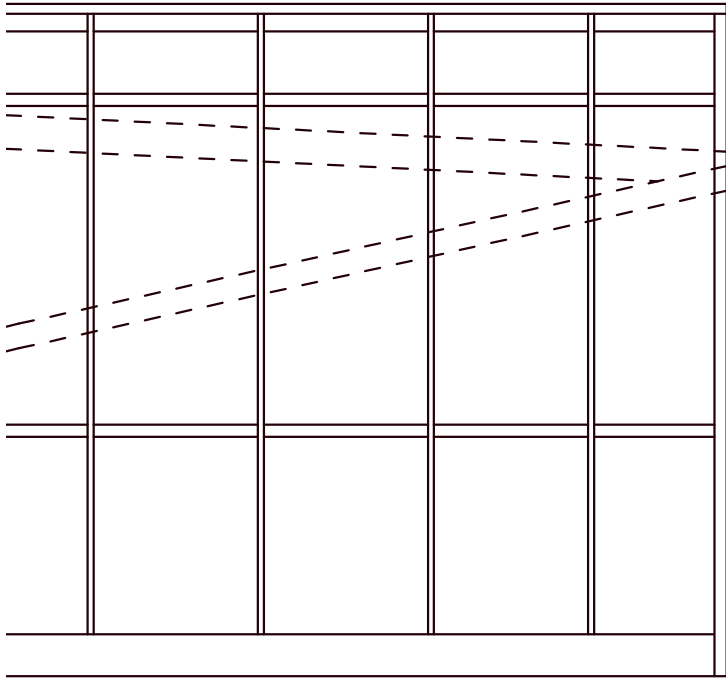

under second last rib

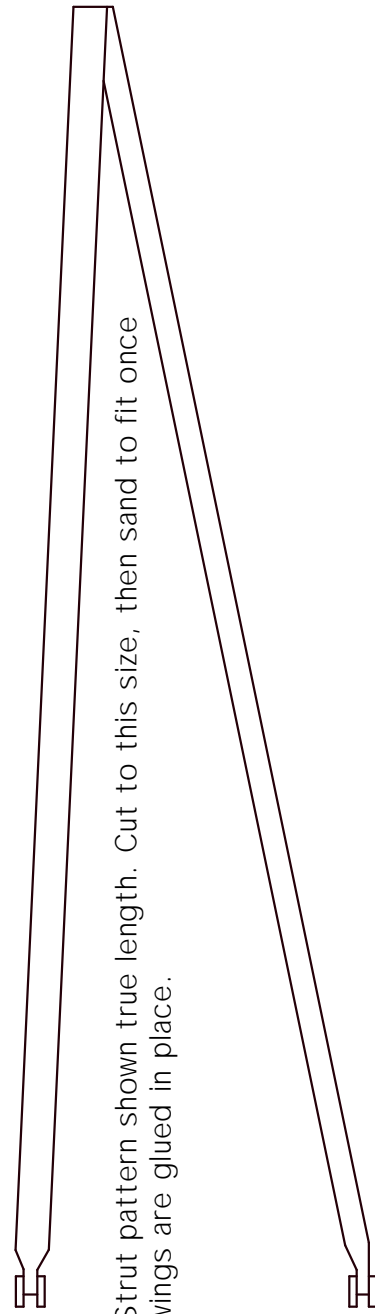
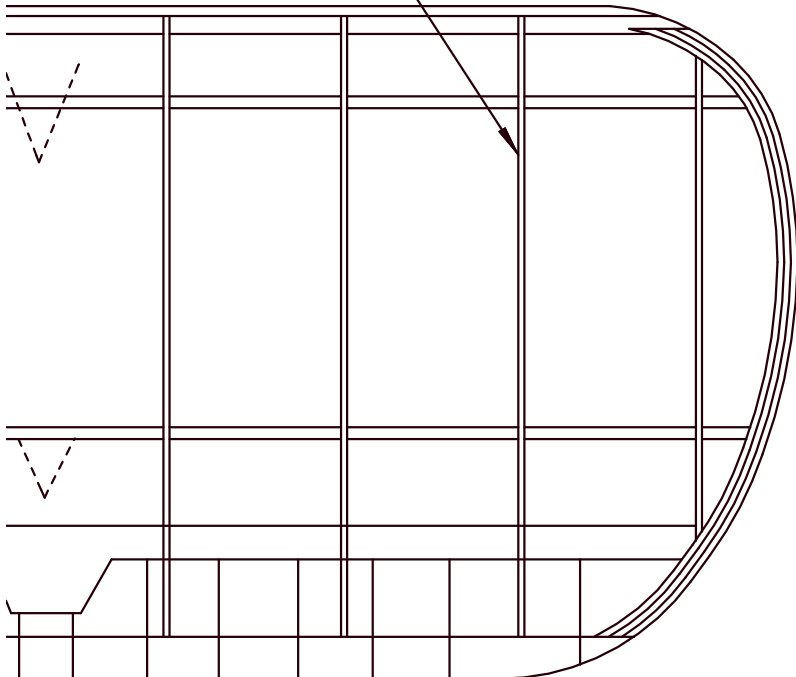

Strut pattern shown true length. Cut to this size, then sand to fit once wings are glued in place.

Wing tips are laminated from 3 layers of 1.6mm x 0.8mm balsa. Photo-copy the plan, then glue it to a piece of scrap balsa to make a template. Soak strips in water & white glue, tape them around the template, then leave overnight to dry.

Nose cross-section using Peck Polymers style thrust button (large):

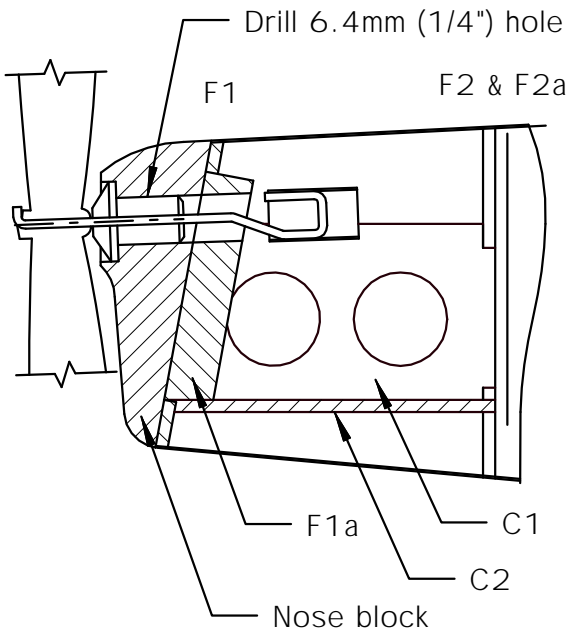

Nose cross-section using Gizmo Geezer Precision Free Wheeler:

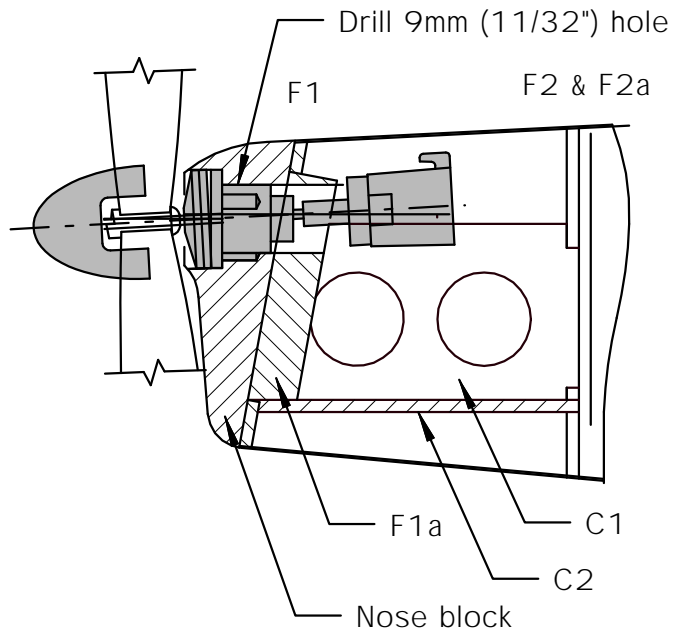

Tail-plane ribs and spars from 1.6mm square balsa strip.

Tail-plane outlines laminated from 3 layers of 1.6mm x 0.8mm balsa. Structure follows full size aircraft.

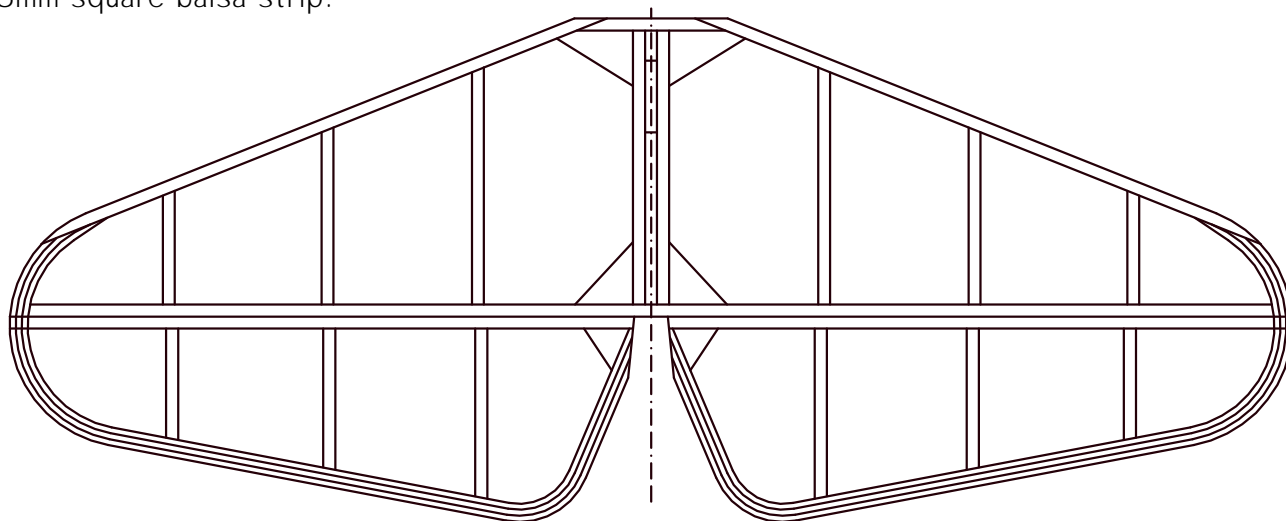

Construction sequence: solid rib construction:

1. Cut ribs from sheet. 2 off 1.6mm and 24 off 3.2mm.

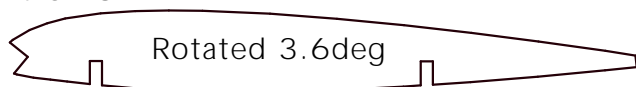

2. Cut and notch spars, then place on building board over plan. Support spars on 1.6mm shims, and use several ribs (without glue at this stage) to position spars.



3. Slide ribs into position in slots and glue in place.



4. Add 3.2mm square leading edge.



5. Raise front of wing (pack front spar up by 4.8 mm) and glue trailing edge to rear of ribs.



6. Sand LE and TE to shape (TE is sanded on top only).



Construction sequence: sliced rib construction:

1. Slice upper & lower rib sections from sheet using the templates shown on this plan. 2 off 1.6mm and 24 off 3.2mm (upper and lower).



2. Place the LE directly on the building board, and shim the spars up by 0.5mm



3. Glue the top rib sections in place.



4. Turn the wing over and glue bottom rib sections in place.

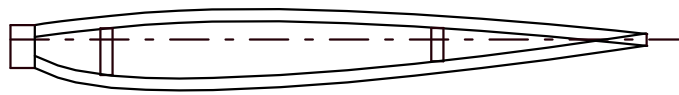

5. Turn the wing upright again, and raise the leading edge (pack the forward spar with a 6.4 mm shim). Sand a slight angle on one side of the TE to match the rear edge of the ribs, then glue the TE in place.

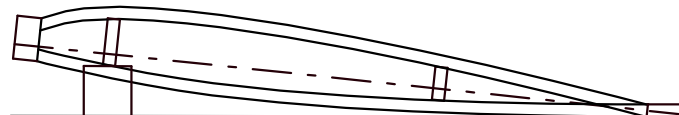

6. Sand LE and TE to shape (TE is sanded on top only).

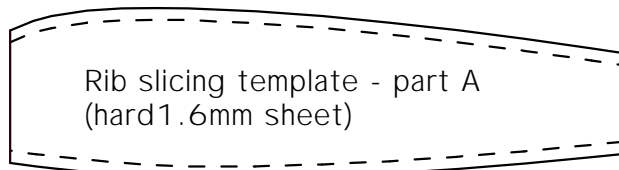

Rib slicing template - part A  
(hard 1.6mm sheet)

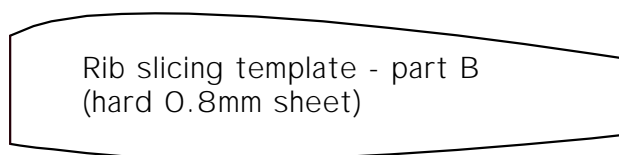

Rib slicing template - part B  
(hard 0.8mm sheet)

Fuselage construction sequence:

1. Build basic side frame (shaded in gray) over the plan. Build one side frame, then build a second over the top of the first. Lift these frames off the board and separate.

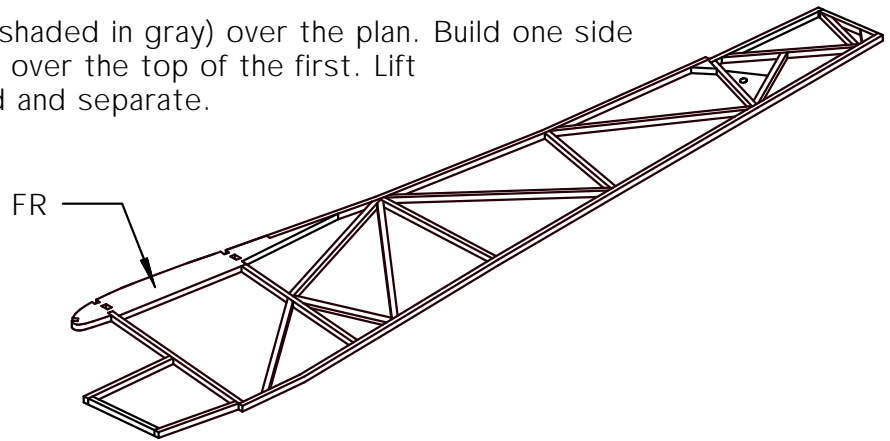

2. With each side frame flat on the building board, glue formers F3S, F4S and F4L to the basic framework. Make sure you make one left side and one right side frame!

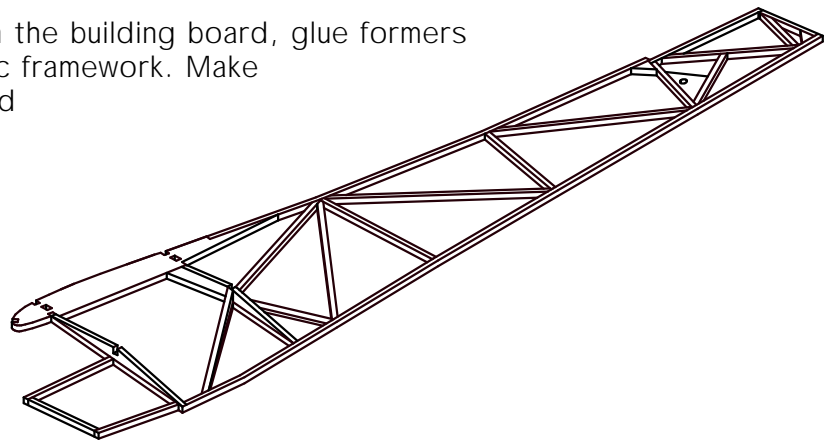

3. Carefully crack FR at the position of F4, and crack the lower longeron at the position marked. Raise the rear of the fuselage by 12.8mm lower the front to the building board. Then glue the rear window frames in place, as well as the rear stringers (0.8 x 1.6mm).

