

125mm (5") Prop

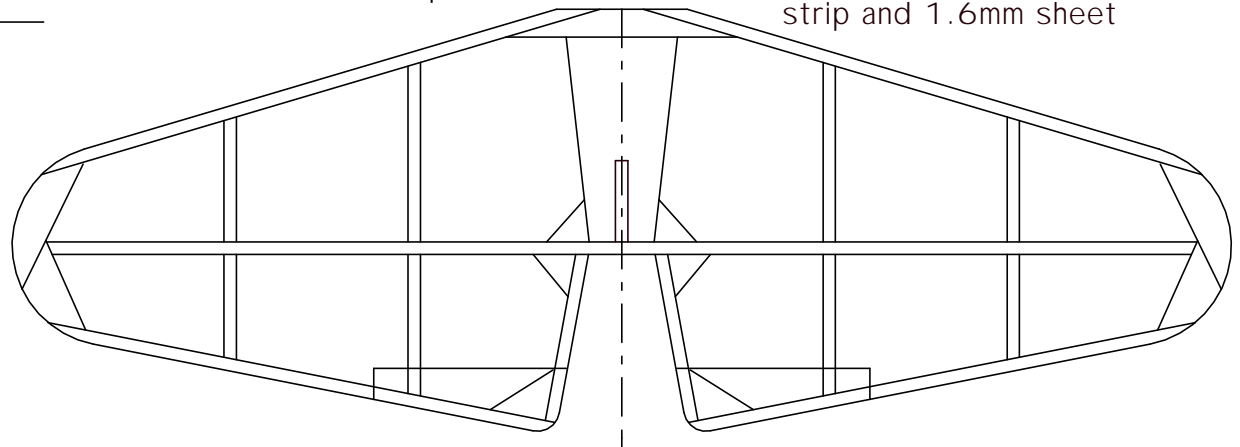

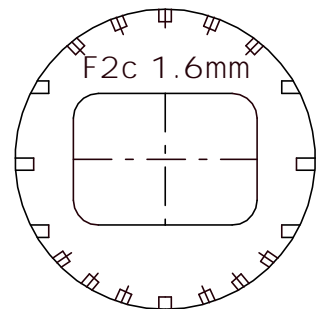

F10T

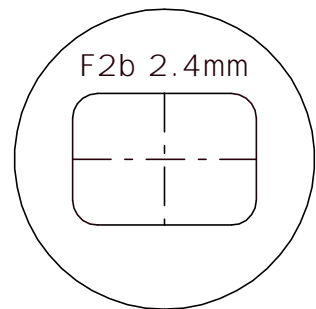
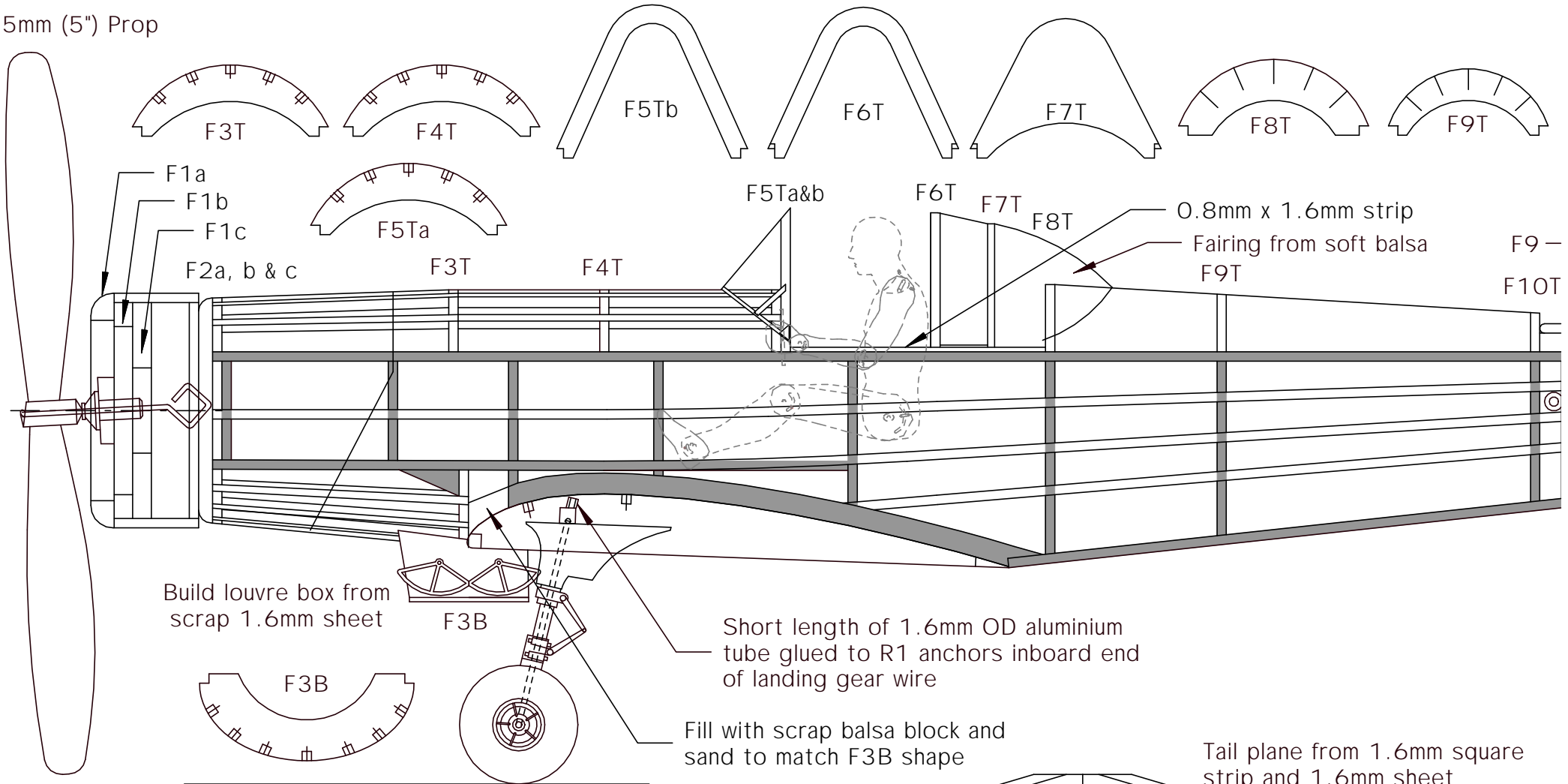
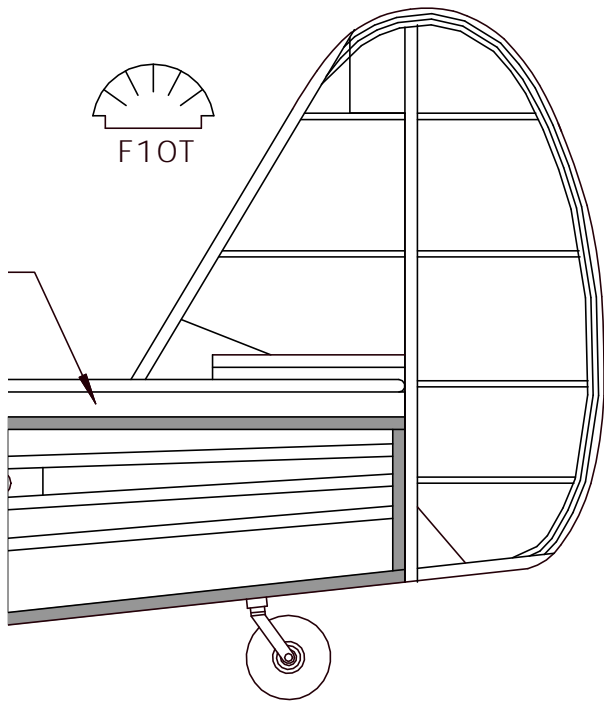
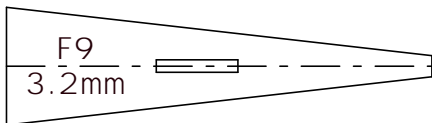

F9
3.2mm

Bend undercarriage from 0.8mm (0.032") piano wire. Bend 2 the same.

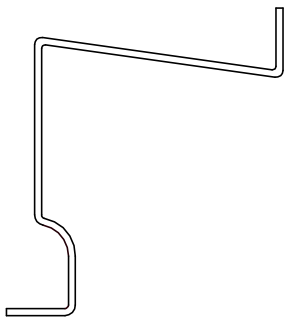

Metric conversions:

0.8mm	1/32"
1.6mm	1/16"
2.4mm	3/32"
3.2mm	1/8"
4.8mm	3/16"
6.4mm	1/4"

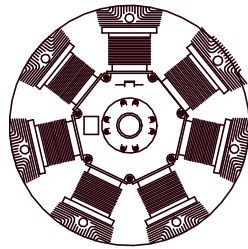

Details of the Warner Scarab 7-cylinder radial engine

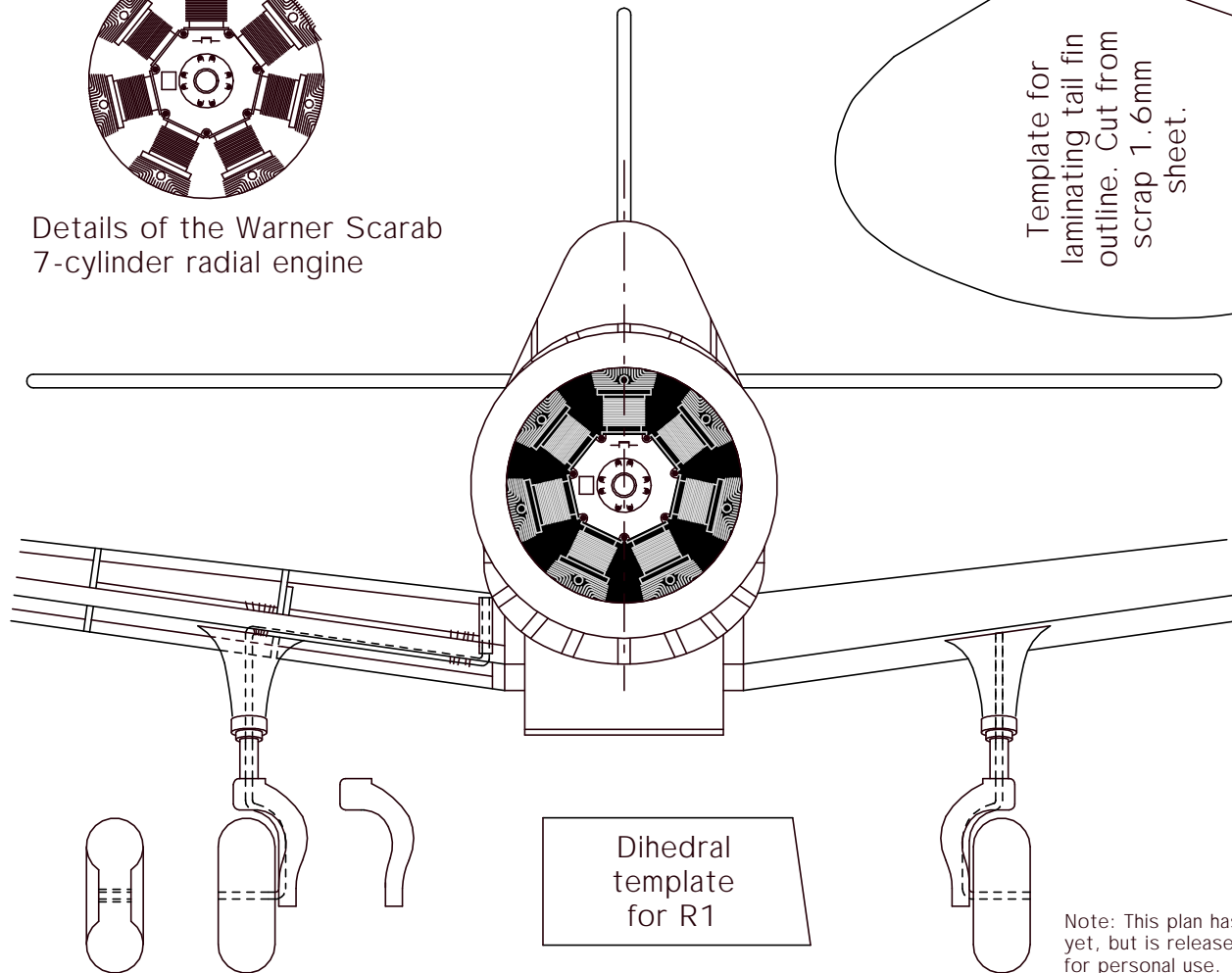

Dihedral
template
for R1

Template for
laminating tail fin
outline. Cut from
scrap 1.6mm
sheet.

Note: This plan has **not** been test-flown yet, but is released free of charge for personal use.

Kingsford Smith Aviation Services KS-3

A rubber powered flying scale model of a 1950's Australian cropduster

Dimensions:	Prototype:	Model:	
Span:	11.28 m	470 mm	(18.5")
Length:	7.93 m	351 mm	(13.8")
Wing area:	17.09 m ²	2.97 dm ²	(46 in ²)
Weight:	1,188 kg	28 g	(1.0 oz)
Wing loading:	14.1 lb/ft ²	9.43 g/dm ²	(3.1 oz/ft ²)
Power:	175 hp Scarab	1 loop 3.2 x 300 mm	
Scale:		1 : 24	

Model designed by
Derek Buckmaster
April 2003

© D Buckmaster 2003
e-mail:
derekb@unite.com.au

Leading edge 2.4mm square

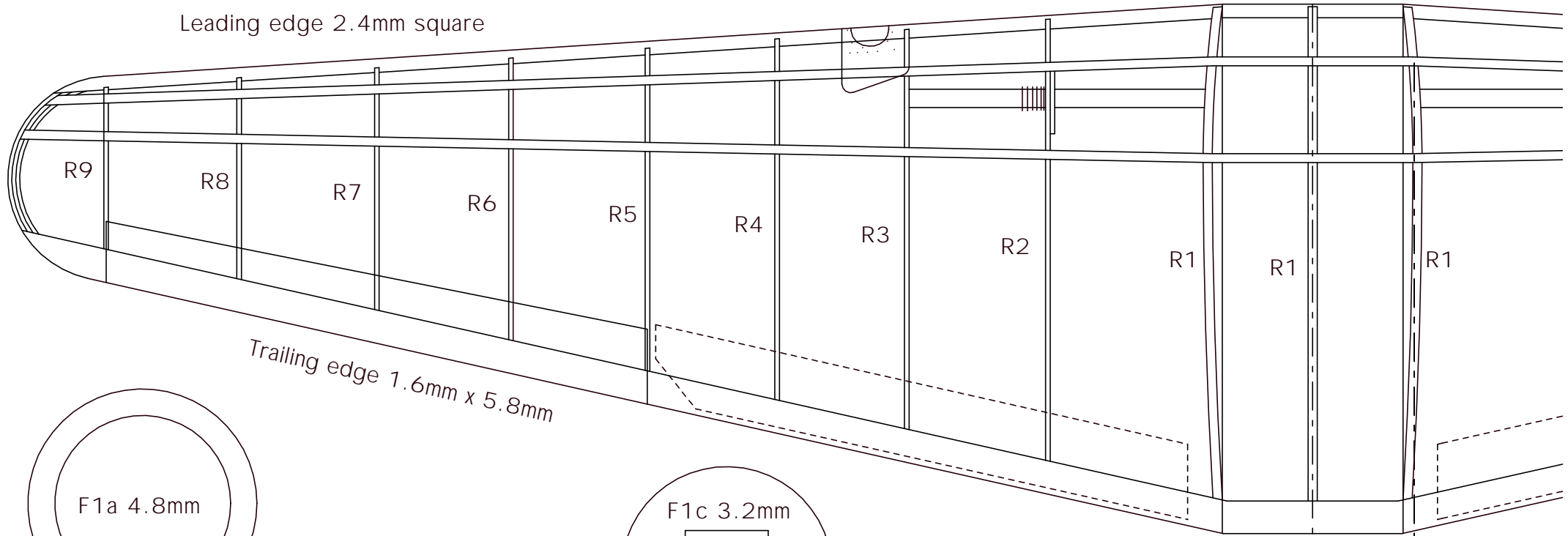

Trailing edge 1.6mm x 5.8mm

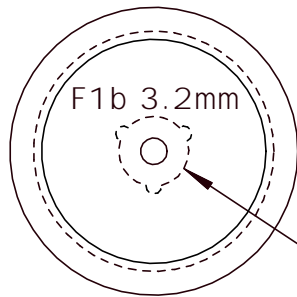
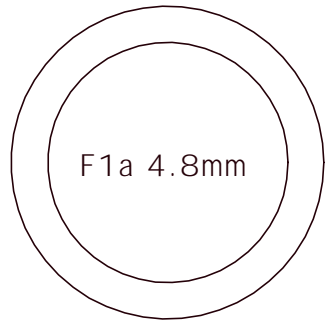

Hole if using
Gizmo Geezer
precision free-wheeler

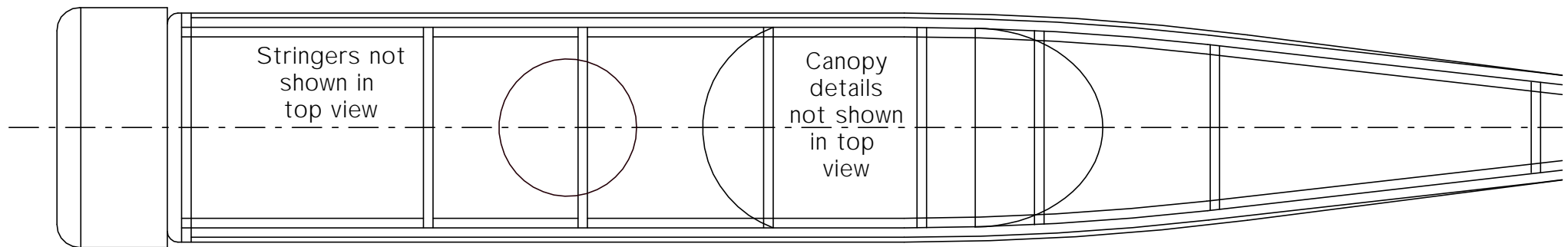
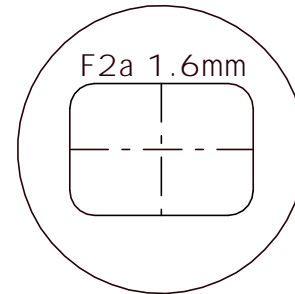
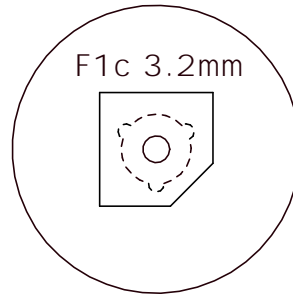

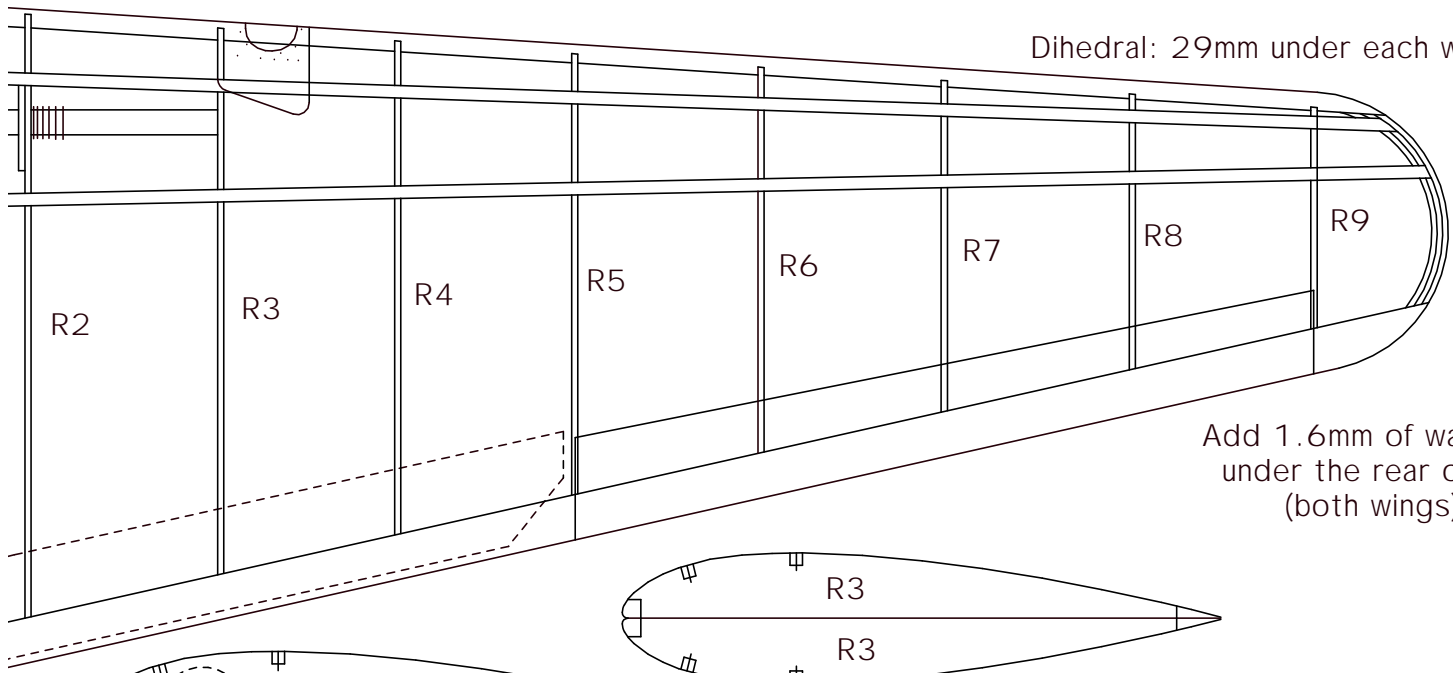

Add 1.6mm of washout under the rear of R9 (both wings)

Installation details if using a Gizmo Geezer Precision Free Wheeling front end. Drill a 9mm hole in F1b and file 3 small slots at 120°. Note: KS-3s did not have spinners.

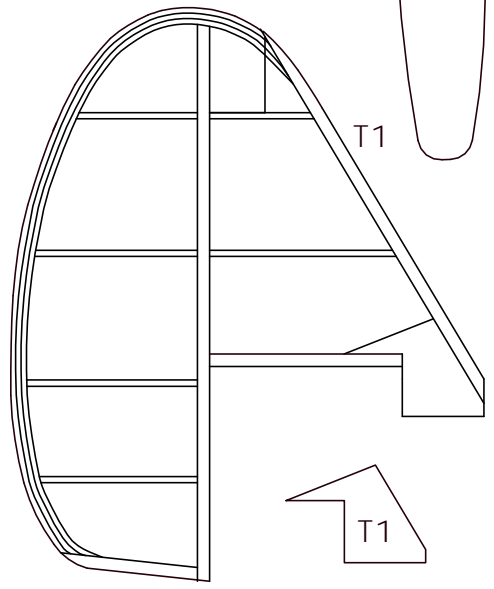
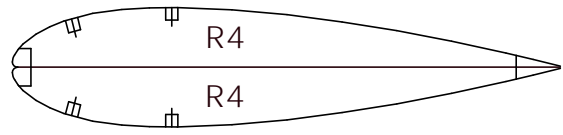
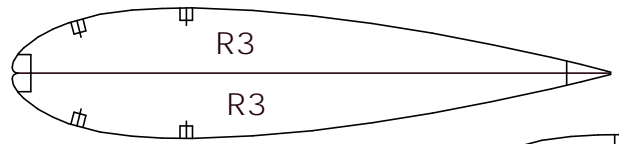
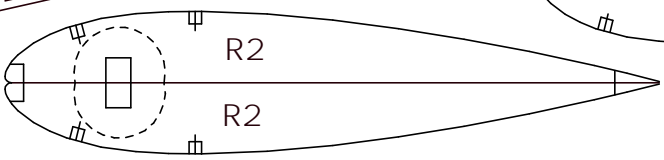
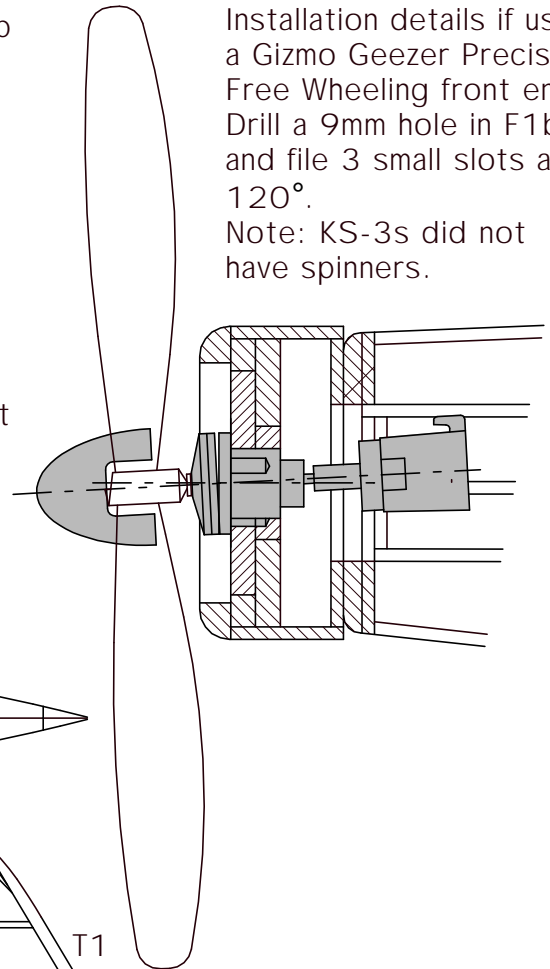

Wing tip laminating template

