

Note: This plan has **not** been test-flown yet, but is released free of charge for personal use.

Metric conversions:

0.8mm 1/32"
 1.6mm 1/16"
 2.4mm 3/32"
 3.2mm 1/8"
 4.8mm 3/16"
 6.4mm 1/4"

Sheet 5 of 6

Yeoman Aviation Cropmaster Metal Tail Testbed VH-AIV

A rubber powered flying scale model of a 1950's Australian cropduster

Dimensions:	Prototype:	Model:
Span:	10.36 m	610 mm (24")
Length:	8.08 m	443 mm (17.5")
Wing area:	16.50 m ²	5.70 dm ² (88.4 in ²)
Weight:	1,542 kg	70 g (2.5 oz)
Wing loading:	19.1 lb/ft ²	12.28 g/dm ² (4.0 oz/ft ²)
Power:	250 hp	2 loops 3.2 x 600 mm
Scale:		1 : 17

Model designed by
 Derek Buckmaster
 December 2002

© D Buckmaster 2002
 e-mail:
 derekb@unite.com.au

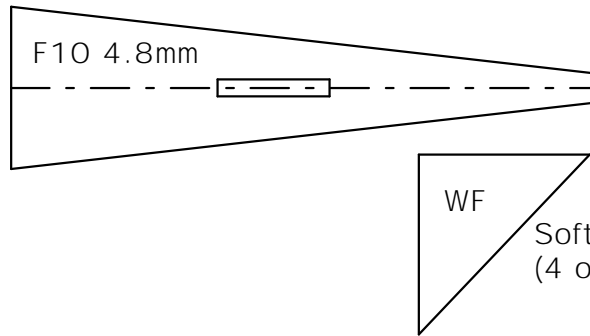
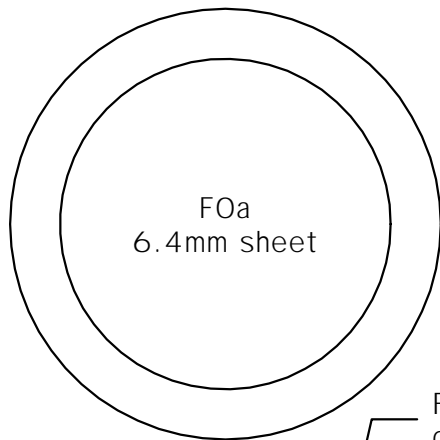

Soft 6.4mm sheet
(4 off)

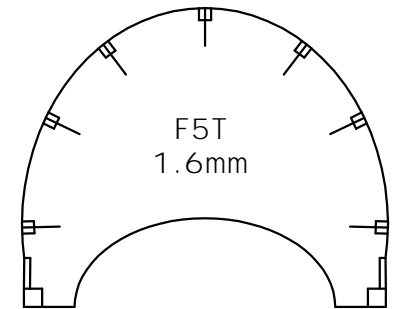

Fill this section with sheet to support landing gear mounts at W1, W2 and W3

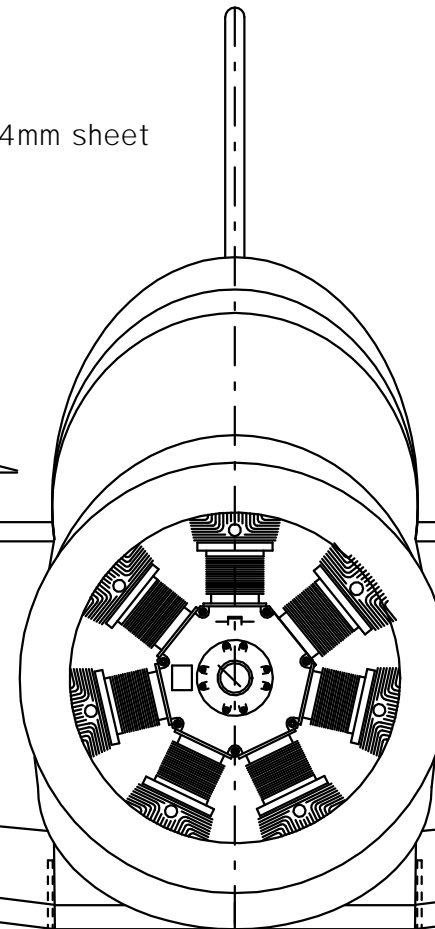

Landing gear.
Bend from 0.81mm diameter
(0.032 gauge) piano wire.
2 required.

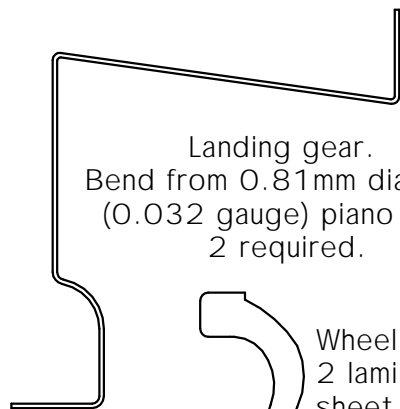

Wheel struts from
2 laminations of 3.2mm
sheet (4 off)

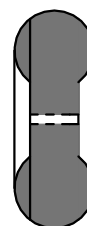
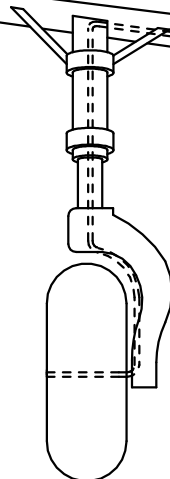

Wheels turned from sheet balsa.
Middle lamination 6.4mm, side
laminations 2.4mm.
1.6mm OD aluminium tubing for
bearing.

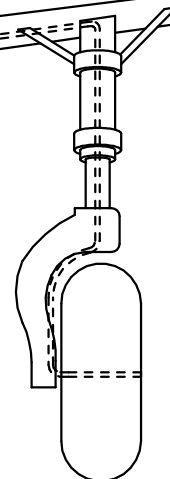

Nose construction showing
installation of Gizmo
Geezer Precision Free
Wheeler front end.

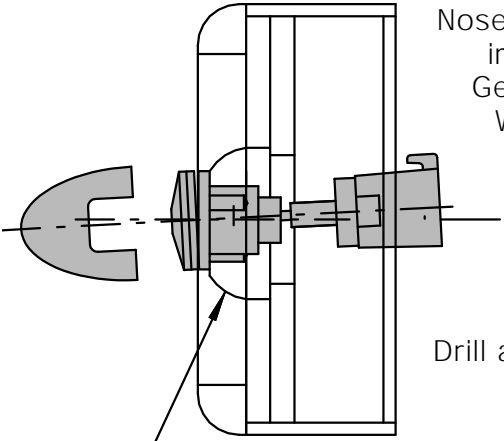

Drill a 13mm diameter
hole in FOa.

Dummy crank-
case from
4.8mm sheet

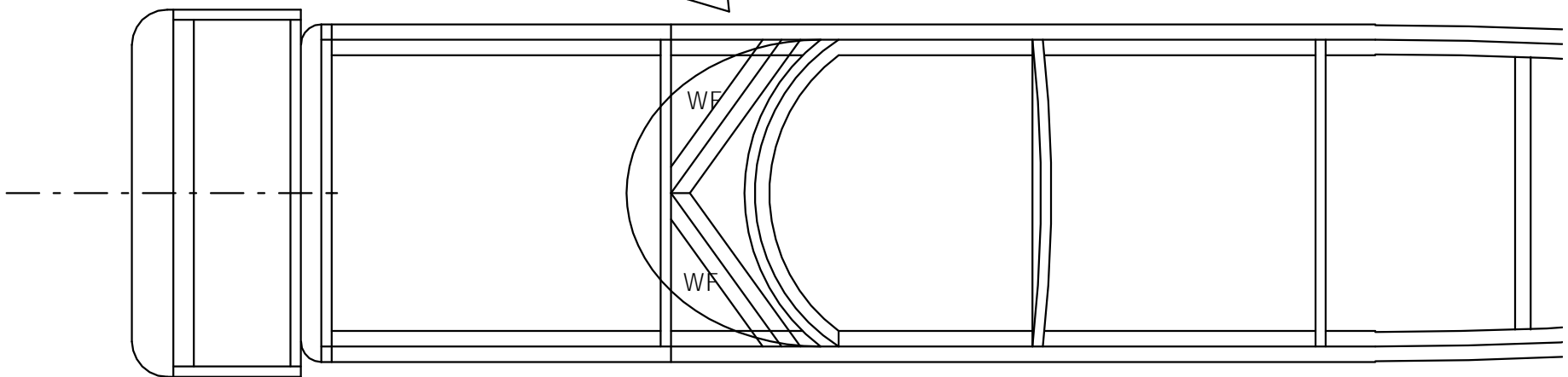
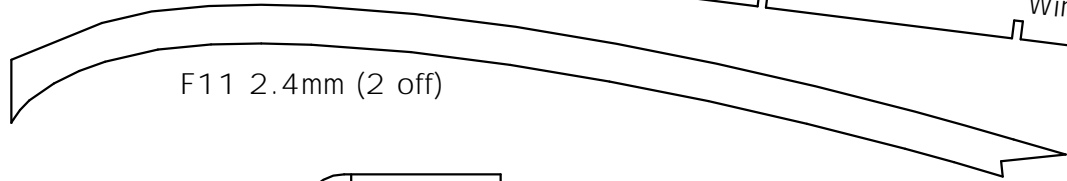
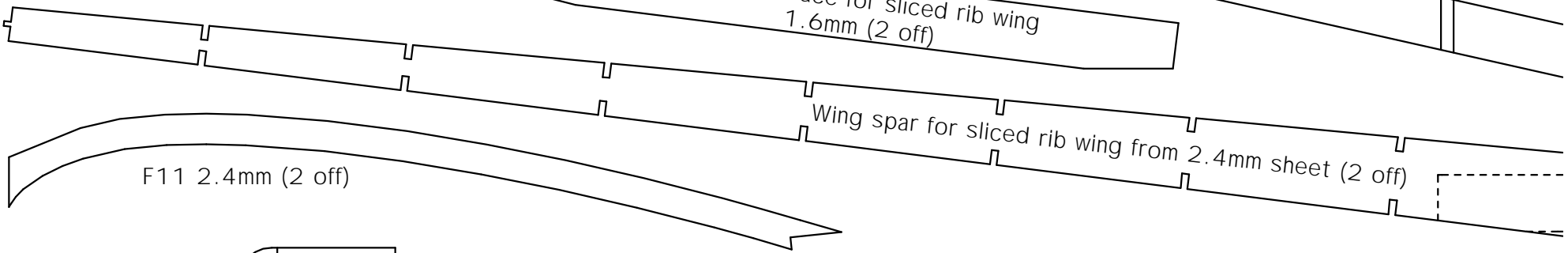
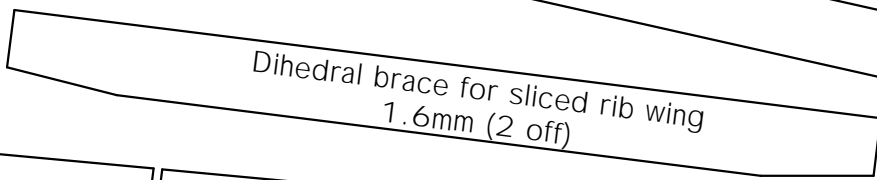
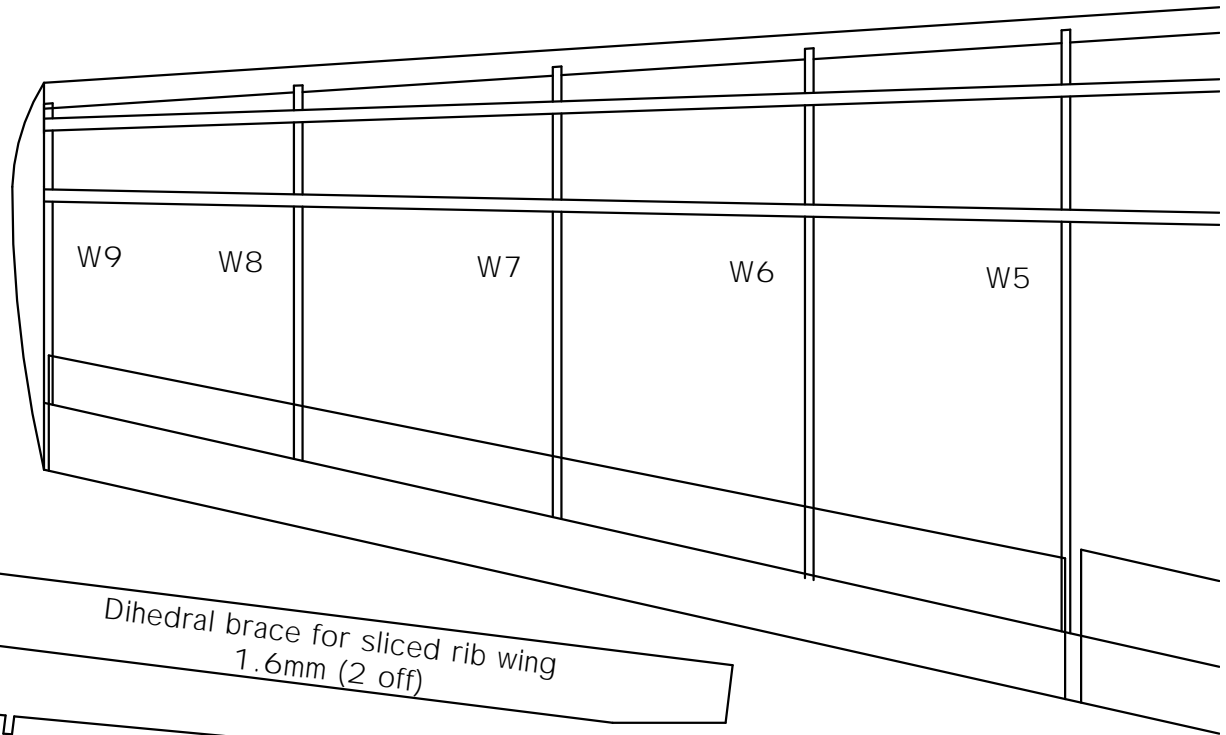
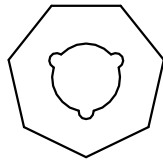

4.5mm

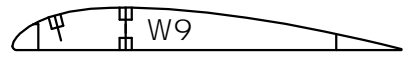
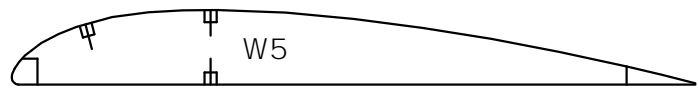
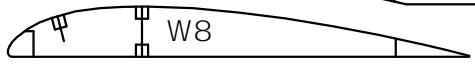
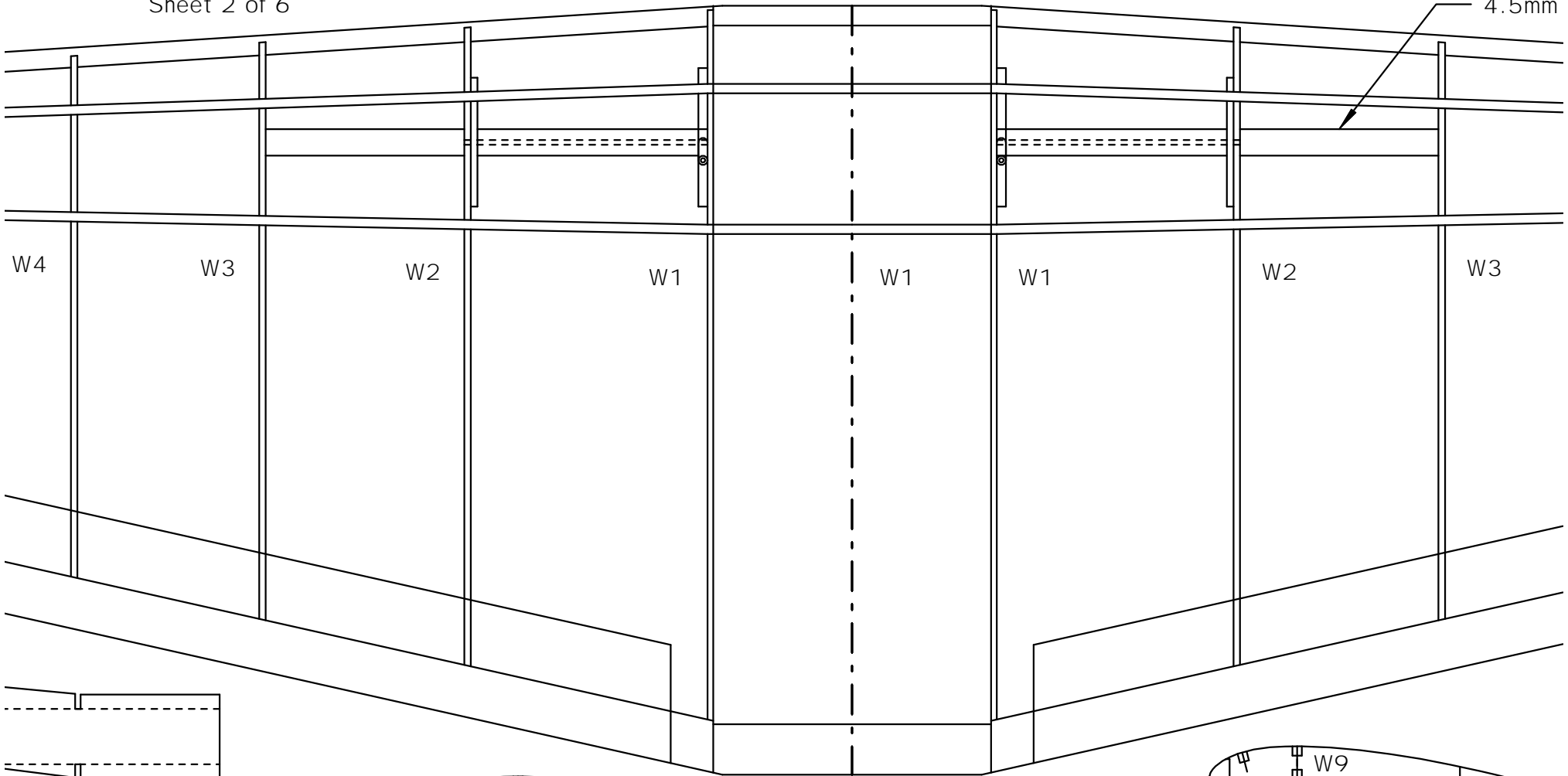

All wing ribs from 1.6mm sheet

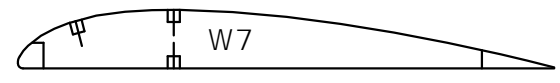
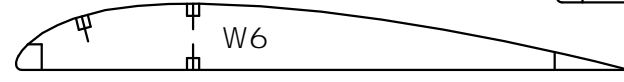
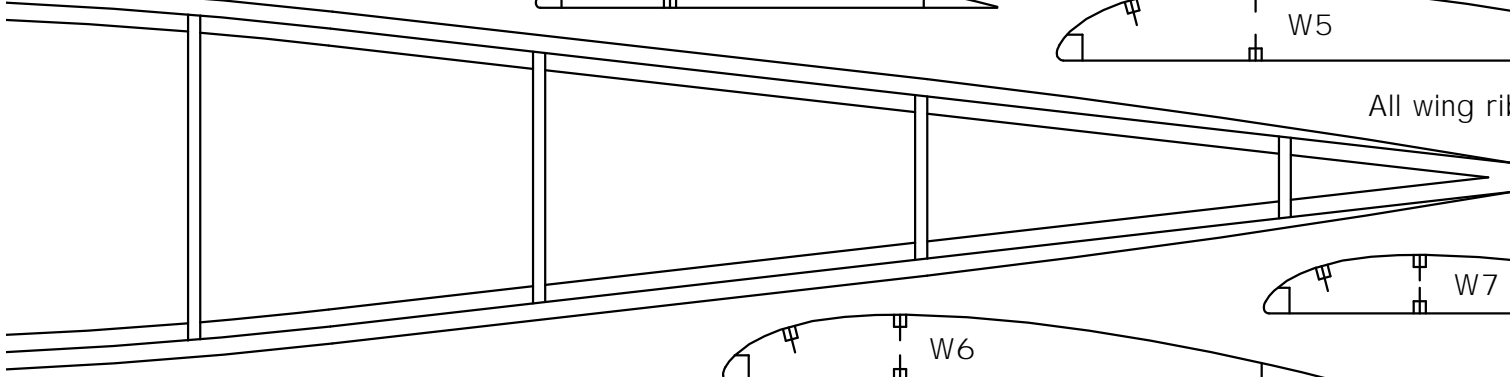

Dummy crank-case
4.8mm sheet

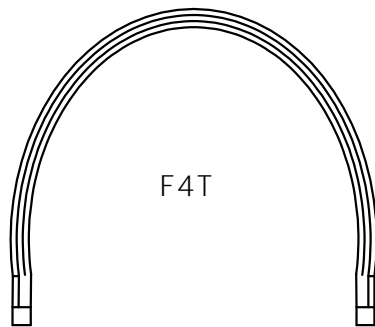
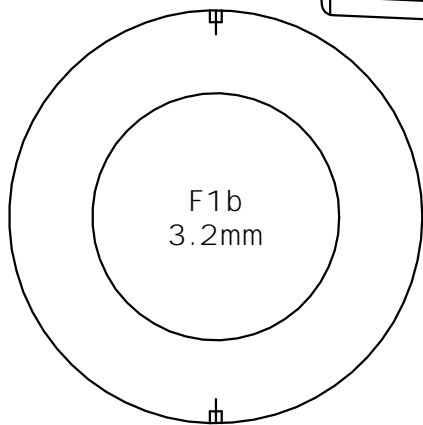
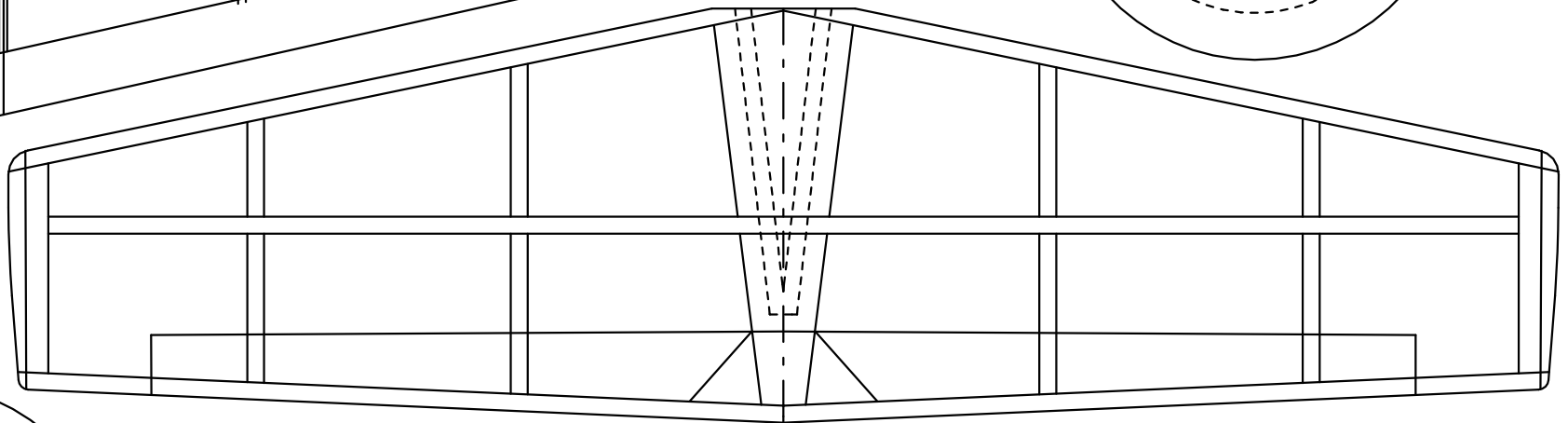
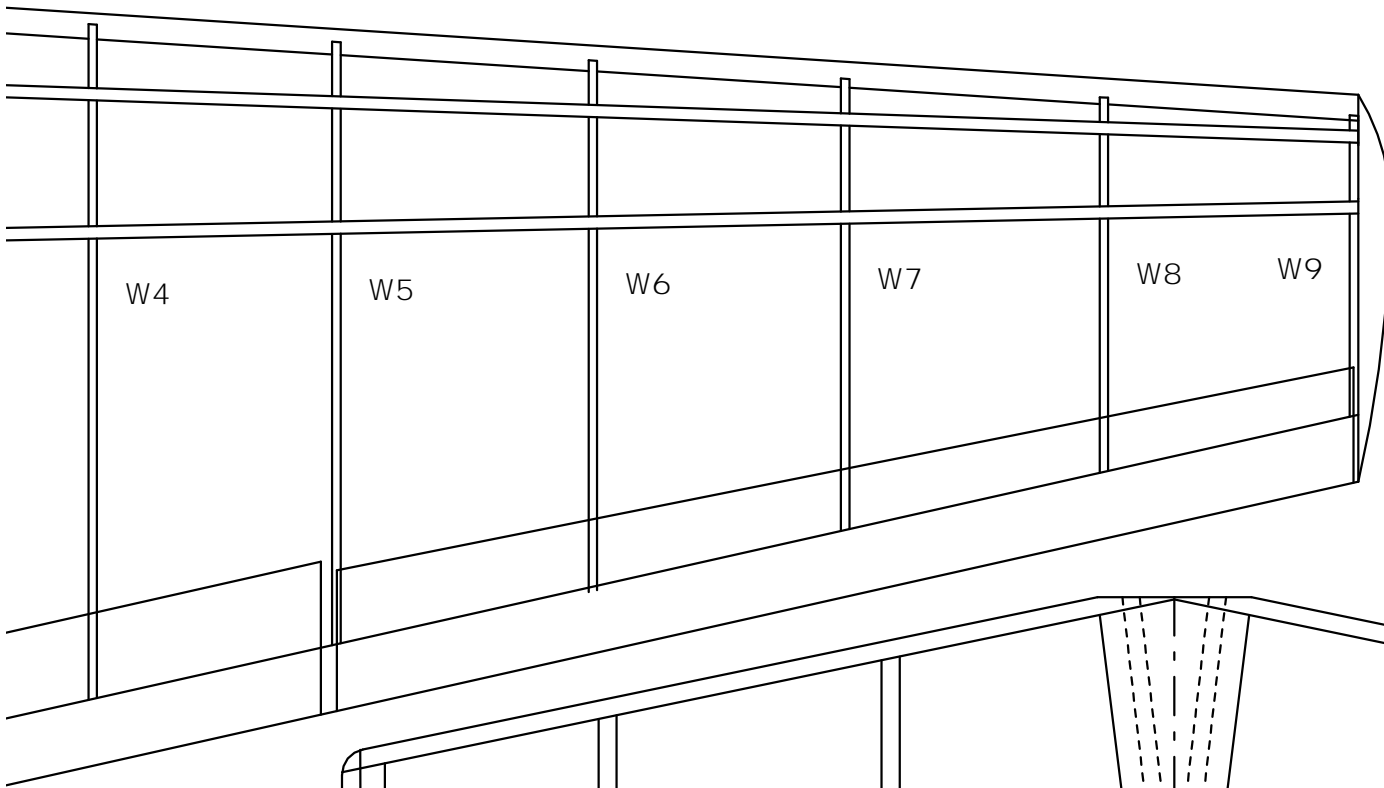
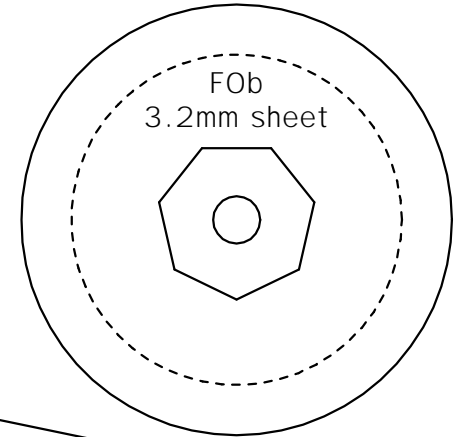
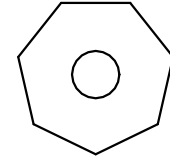

Tail plane constructed
from 2.4mm square strip
and 2.4mm sheet

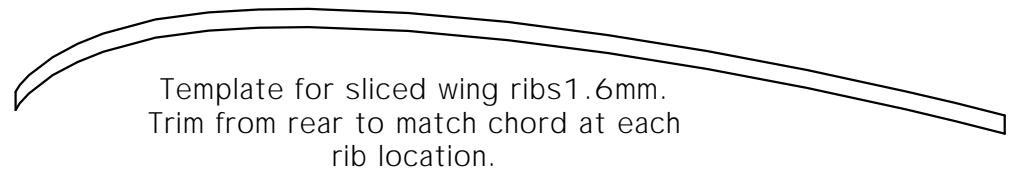

Template for sliced wing ribs 1.6mm.
Trim from rear to match chord at each
rib location.